

SCANLAN®

# Van Gompel™ Suction System

Developed in cooperation with Jamie J. Van Gompel, M.D.

The SCANLAN® Van Gompel™ Suction System is designed to provide control to atraumatically retract, probe, lift, and evacuate fluid or tissue from the surgical field. The Van Gompel™ system offers a choice of three sizes and the SCANLAN® universal suction handle accommodates all tip diameters.



Feel the Difference of Precision Craftsmanship



Highest Quality Surgical Instruments  
Since 1921

SCANLAN®

# Van Gompel™ Suction System

## Features:

- Atraumatic tips may be used to retract or probe delicate tissue
- Fingertip control for atraumatic tissue manipulation or aspiration
- Each suction tip is tapered to reduce clogging
- Unique manufacturing process eliminates “crimping” at the 90° and 45° bends to further lessen the potential for clogging
- One universal suction handle accommodates every tip configuration
- Tips and handle separate for cleaning and sterilization

SCANLAN®

## Van Gompel™ Suction Tips

Developed in cooperation with Jamie J. Van Gompel, M.D.

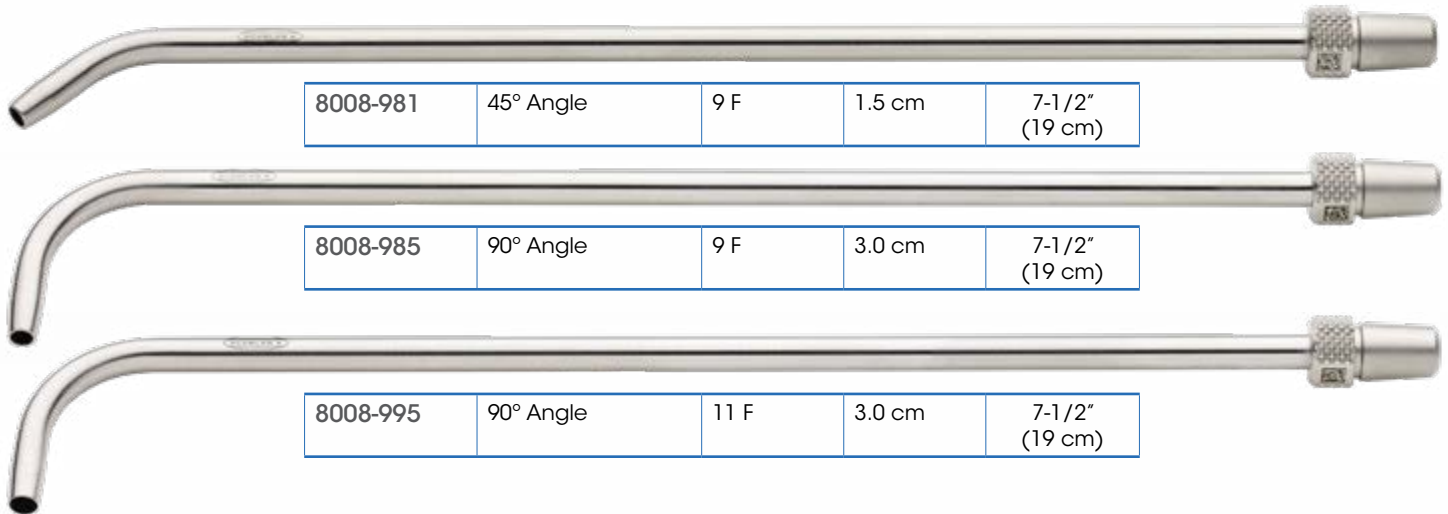

8008-981	45° Angle	9 F	1.5 cm	7-1/2" (19 cm)
----------	-----------	-----	--------	----------------

8008-985	90° Angle	9 F	3.0 cm	7-1/2" (19 cm)
----------	-----------	-----	--------	----------------

8008-995	90° Angle	11 F	3.0 cm	7-1/2" (19 cm)
----------	-----------	------	--------	----------------

SCANLAN®

## Universal Suction Handle



Cat. No.	Description	Total Length
9009-930	Universal Suction Handle (Fits all tip lengths and french sizes)	3" (7.5 cm)

For Non-CE Distribution

**For more information or to place an order,**  
please contact your local Scanlan representative, or call...

U.S. & Canada: 800-328-9458 International: 651-298-0997  
[www.scanlaninternational.com](http://www.scanlaninternational.com)

SCANLAN®

## V.I.P.™ Sterilization Tray



Cat. No.	Description	Total Length
2136-03	SCANLAN® V.I.P.™ Sterilization Tray, with Scan-Guard™ silicone brackets in base	6" x 9" x 2" (15 cm x 23 cm x 5 cm)



Each Scanlan instrument is individually handcrafted to provide the surgeon with the highest quality, longest-lasting, precision instrument possible. Reflecting this unique process, all stated dimensions are approximate.

Not all products are available in all regions. Please consult your Scanlan Representative for products available in your region.

Please check with your Scanlan Representative for Firm Sale status. Custom modifications may be available upon request.



MK-B-VGSS Rev. B